

WSD

Class Balustrade Design – Safety Considerations

Safety Design in Buildings Conference
– Muscat 2017

Andy Dean FCIQB, FSFE

Head of Façades

Safety Design in Buildings

Muscat Conference

Monday, November 06, 2017, Crowne Plaza Muscat



Learning objectives

1. The object of this presentation is to provide an understanding of particular aspects of glass balustrade design in the context of safety

2

Structure of this presentation – presented by an expert speaker

- bullet points are provided as a speaker aid only



Andy has over 30 years of experience in the field of Building and Construction, ranging from structural testing within the nuclear industry to fire testing. Having established the Dubai Façade Technology Centre and Laboratory in 1997, and operated it for 10 years, he has particular knowledge of heavy structures testing and weathertightness testing of facades, curtain walling and building envelope systems; and business in the Middle East.

Andy is a Fellow of the Chartered Institute of Building, Fellow of the Society of Façade Engineers (CIBSE) and member of the Glass and Glazing Federation; holding or having held senior committee positions in the local chapters of these organisations.

As a façade consultant he continues to provide input into the GCC codes and is a regular speaker at industry technical seminars across the region.

Copyright Materials

This presentation is protected by international copyright laws. Reproduction, distribution, display and use of the presentation without written permission of the speaker is prohibited.

© WSP Middle East 2017

Overview



Source: Glassplan, London

- Glass selection
- Balustrade purpose
- Main aspects for safety
- Component factors for safety

Glass Selection



Source: United Glass, Auckland

→ Glass Selection Factors

- Colour
- Protection
- Privacy
- Solar control
- Building function
- Fire safety
- Weather
- Weight
- Breakage
- Many more...

Glass Selection – for a Balustrade

7



Source: S-Vision Glass

→ Functions

- Protection
- Separation
- View - clarity
- Wind break
- Ventilation
- Solar control

Glass Selection - for a Balustrade

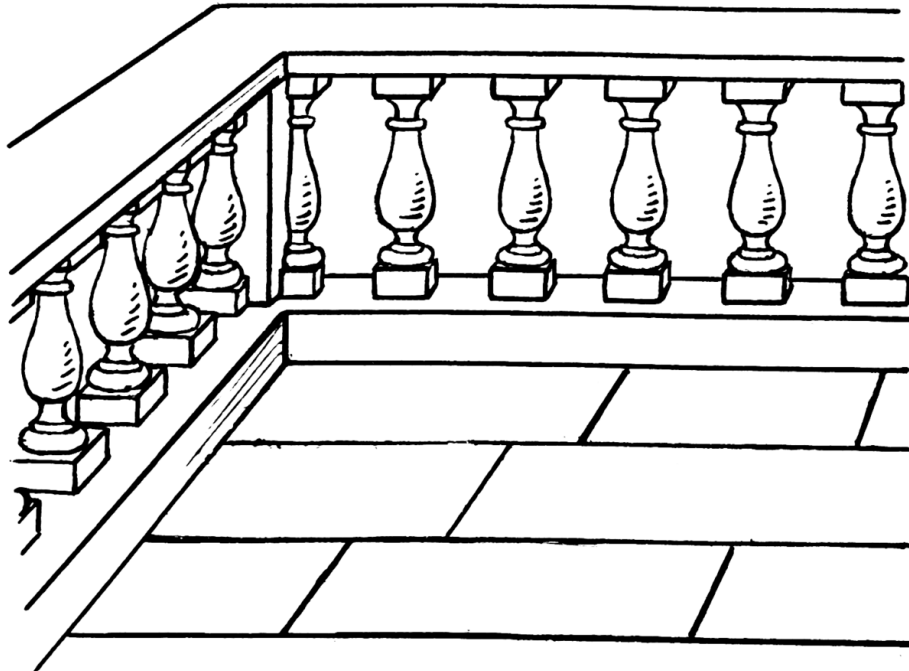

Source: Wikipedia

→ Functions

- Protection
- Separation
- View - clarity
- Wind break
- Ventilation
- Solar control
- Elegant
- Balustre (balaustro, from balaustra, "pomegranate flower")
- Others

Glass Selection – for a Balustrade



Source: Adelaide Balustrade & Fencing

→ Functions - **safety**

- Protection
- Separation

Glass Selection – for a Balustrade



Source: Adelaide Balustrade & Fencing

→ Functions - **safety**

- Protection / Separation
 - from a hazard
 - a fall
 - wildlife
 - traffic
 - wind

Glass Selection – for a Balustrade



Source: Adelaide Balustrade & Fencing

→ Functions - **safety**

- Protection / Separation
 - from a hazard
 - a fall
 - wildlife
 - traffic
 - wind
- for control
 - in a queue
 - down a stair
 - for a crowd

Main Safety Characteristics

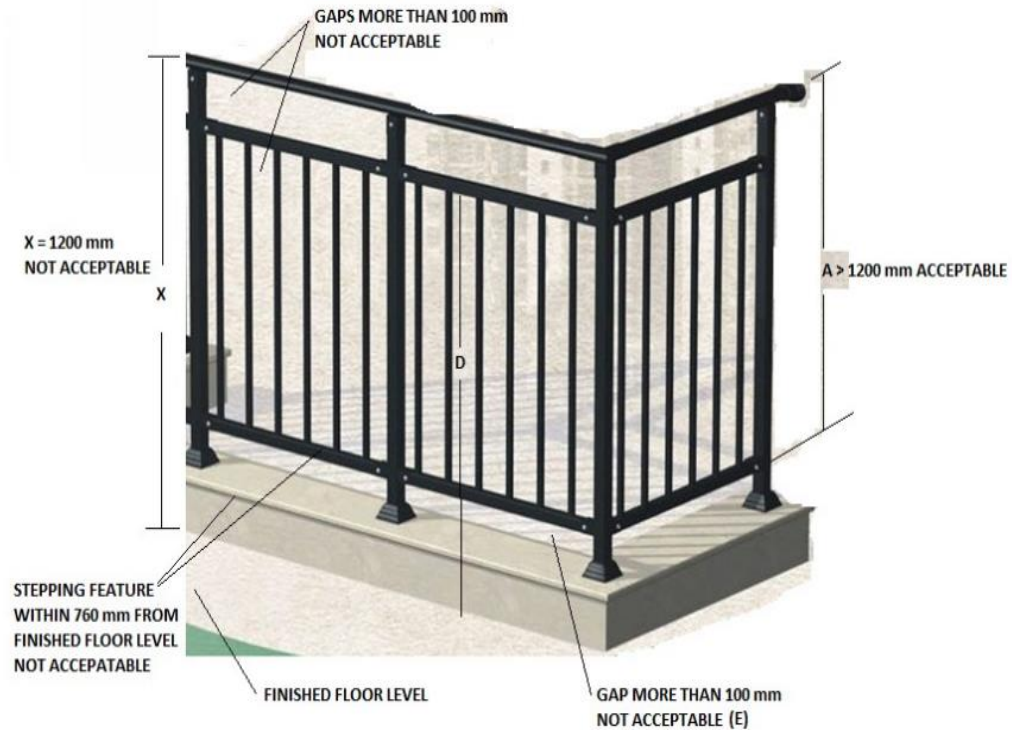

Figure 1.16.b.: Balcony Railing Specifications

Source: UAE F&LS Code of Practice

→ Height

- Typically 1.1m internationally
1.2m in some locations in ME

→ Openings

- Max opening 100mm

→ Climability

- No climbable features up to a certain height (eg. 760mm)
- Max height may start from a rail
- Consider the presence of furniture

→ Strength

- Various loads
- Various conditions
- Various limits

Let's Not Forget Windows – Some Similarities

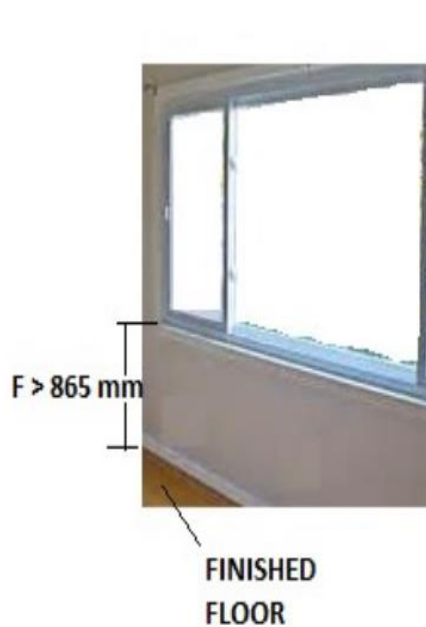

Figure 1.17a: Window Specifications



Figure 1.17b: Window Specifications

Source: UAE F&LS Code of Practice

- A window can provide access to a hazard if opened – effectively becoming a balustrade
- Distance to Window from FFL
 - Usually lower than windows
- Openings
 - Max opening 100mm – sometimes more is allowed
- Climbability
 - Climbable features should be limited
 - The distance limit may start from a climbable feature (e.g. a transom)

Strength



Source: Oxworks

→ Strength

- Various loads
- Various conditions
- Various limits

Strength – Load Sources



Source: Oxworks

→ Strength

- Various loads
 - people
 - wind
 - impact
- Various conditions
- Various limits

Strength – Load Conditions



Source: Oxworks

→ Strength

- Various loads
 - people
 - wind
 - impact
- Various conditions
 - point load
 - UDL
 - Post, panel, rail, etc
- Various limits

Strength – Load Limits / Magnitudes



Source: Oxworks

→ Strength

- Various loads
 - people
 - wind
 - impact
- Various conditions
 - point load
 - UDL
 - Post, panel, rail, etc
- Various limits
 - 0.89kN at any point generally?
 - 1.5kN people?
 - 3.0kN crowd?
 - 4.0kPa wind?
 - Reduction of DWP by 0.4kPa on an external balustrade?

Strength – Aspects to Consider



Source: Yes Glazing Solutions

→ Strength Aspects

- Safety factors - 4
- Post-breakage safety
- Post-breakage capacity
- Methods of capturing the glass
- Calculation of stresses
- Deflection versus stress
- The handrail

Components - Glass



Source: Stairs Direct

- **Components - Glass**
 - **May be an infill panel**

Components - Glass



Source: SHS Products

→ Components - Glass

- May be an infill panel
- May provide the whole structure (cantilever)
- Should not be monolithic
 - potentially limited post-breakage safety
- Therefore laminated
 - two layers bonded by a polymer

Components – Glass – Glass Used in a Laminate



→ Components - Glass

- May be an infill panel
- May provide the whole structure (cantilever)
- Should not be monolithic
 - potentially limited post-breakage safety
- Therefore laminated
 - two layers bonded by a polymer
- Unlikely to be annealed glass
- Could be heat-strengthened (HS)
- Could be fully-tempered (FT) (take care with FT glass)

Components - Glass - Kinds / Types - Annealed



→ Components – Glass - Kinds

- Annealed glass
 - float glass
 - relatively weak
 - susceptible to thermal cracking
- Heat-strengthened (HS)
- Fully-tempered (FT)
(also called toughened)

Components – Glass – Kinds / Types – Heat Strengthened

FLOAT GLASS

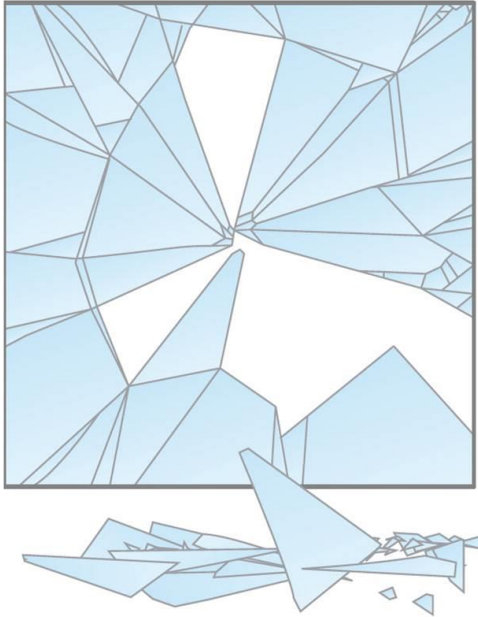

HEAT-STRENGTHENED GLASS

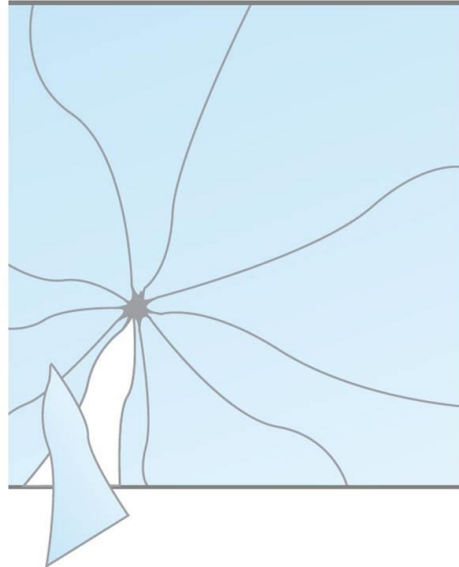

Source: Crystal India

→ Components – Glass - Kinds

- Annealed glass
- Heat-strengthened (HS)
 - 2 x strength of annealed
 - not susceptible to thermal cracking
 - not susceptible to NiS cracking
- Fully-tempered (FT)
(also called toughened)

Components - Laminated FT Glass - Fully Tempered



Source: GGF

→ Components – Glass - Kinds

- Annealed glass
- Heat-strengthened (HS)
- Fully tempered (FT)
 - 5 x strength of annealed
 - not susceptible to thermal cracking
 - susceptible to NiS cracking
- FT in a laminated form...
 - it loses all of its strength on cracking,
 - but retains all of its mass.

Components – Laminated FT Glass - Various Interlayers



Source: GGF

→ Components – Laminated FT Glass

- These videos show:
 - 1. a PVB interlayer
 - 2. a structural interlayer (SentryGlasPlus)
- The difference is the post-breakage safety / capacity
- Consider the temperature when calculating capacity. Calcs typically done at 22°C may fail at 50°C.

Components – Posts and Fixings



Source: Stairs Direct

- **Components – Posts and Fixings**
- Posts may provide the support
 - There may be a combination of post, panel and handrail
 - Fixings capture the glass from the posts
 - Consider deflection versus stress
 - deflection may not be a concern in high wind load applications

Components – Posts and Fixings



Source: Mirrors and Glass UK

- **Components – Posts and Fixings**
- Posts may provide the support
 - There may be a combination of post, panel and handrail
 - Fixings capture the glass from the posts
 - Consider deflection versus stress
 - deflection may not be a concern in high wind load applications
 - The highest stresses are likely to be at the fixings

Components – Base Channel



Source: Pinterest

- **Components – Base Channel**
 - Many calculations show a cantilever glass balustrade like this

Components – Base Channel



Source: SZG Glass

→ Components – Base Channel

- But the reality is more like this
- Fine, but the calculation must reflect the reality

Components – Base Channel

BRITISH STANDARD

BS 6180:2011

Figure B.2 Typical clamping systems for free-standing toughened glass balustrades (continued)

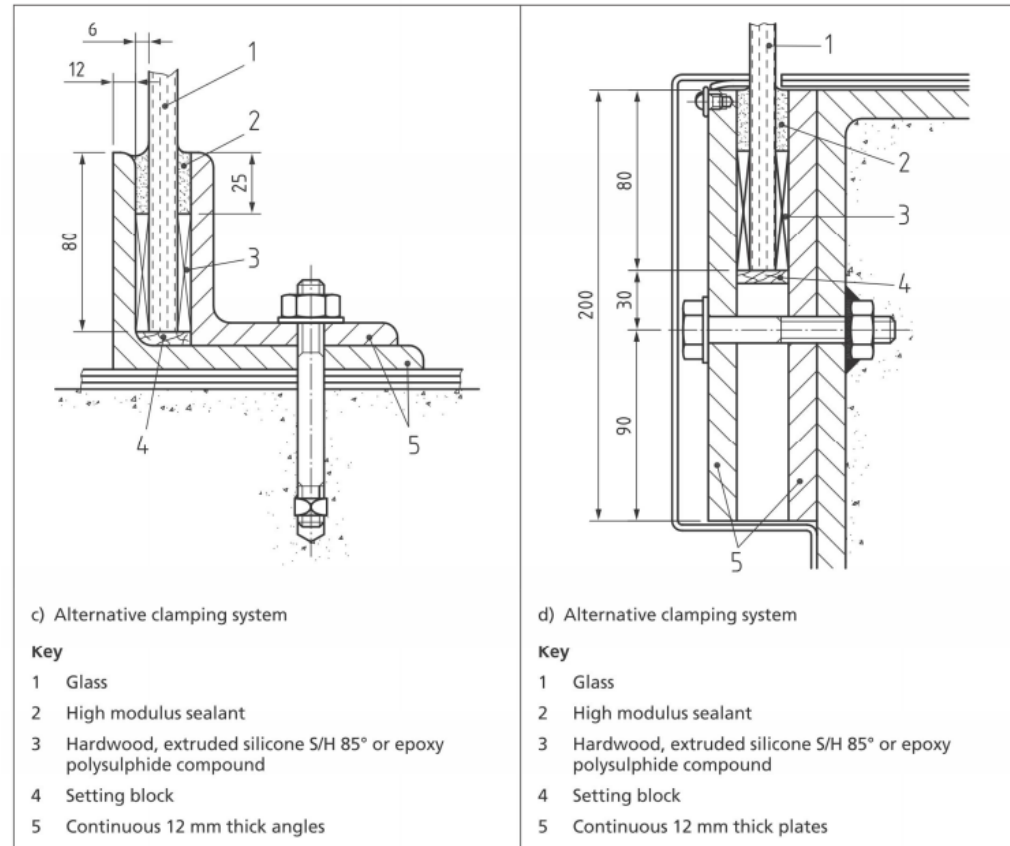

→ Components – Base Channel

- Guidance from the Standards
- Provide either:

- packing and a high modulus sealant (as per the image)

- a grout and weather seal (so, in the context of the image, 3 would be grout, and 2 would be a low modulus weather seal)

- This is often incorrectly only packing and weather seal – therefore offering limited support

Source: BS 6180

Components – Base Channel



- **Components – Base Channel**
- Alternatively use proprietary systems
 - Suggest asking for test reports
 - Consider testing all types (sustained load – not just impact)

Components - Handrail



Source: DuPont

→ Components - Handrail

- Contributes to load capacity?
- Connects multiple panels
- Protects the glass edge from you
- Protects you from the glass edge

Components - Handrail



→ Components - Handrail

- Contributes to load capacity?
- Connects multiple panels
- Protects the glass edge from you
- Protects you from the glass edge
- **Necessary on a stair**

Components - Handrail



Source: Frameless Impressions

→ Components - Handrail

- Contributes to load capacity?
- Connects multiple panels
- Protects the glass edge from you
- Protects you from the glass edge
- Necessary on a stair
- Consider the material
 - bare metal in the ME can get hot (coated metal is usually cooler)
- Consider the shape – no surfaces for ornaments / objects / etc
- May be required by some authorities if the hazard is a fall

Summary



→ Summary

- Consider all of the conditions of the application and legal requirements
- Select the glass carefully
- Consider post-breakage safety
- Make sure that the support condition is represented in the calculations
- Review the interaction of the components and where they are required.

Thank you!

Andy Dean
andy.dean@wsp.com

wsp.com

wsp