



# Riyadh Conference

April 09, 2019, Mövenpick Hotel - Riyadh

## Welcome

### Integration of Passive Fire Safety Code Requirements in Building Design using BIM, AR, VR and AI

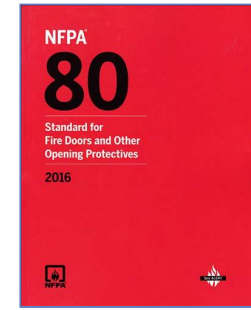
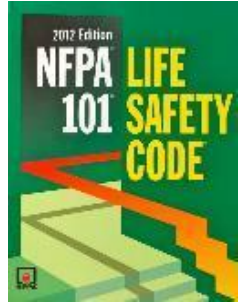

# Active and Passive Fire Protections Systems.

## Detection



## Suppression



Active Components (Need trigger)

## Containment

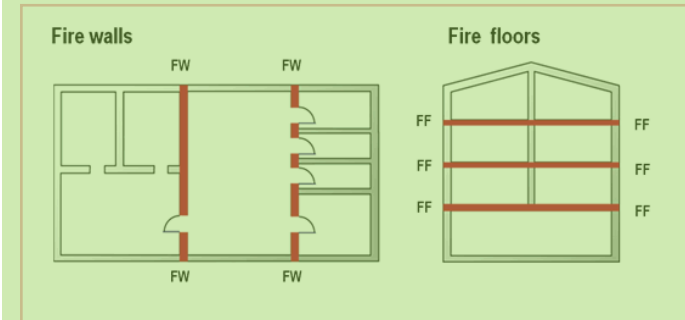

Passive Components (Always there)

## Active Fire Protection

Is a group of systems that require some amount of action in order to work efficiently in the event of a fire. (Fire extinguisher, Sprinkler etc.)

## Passive Fire Protection

Is a group of systems that compartmentalize a building through the use of fire-resistance rated walls and floors, keeping the fire from spreading quickly and providing time to escape for people in the building. (Dampers, Fire Doors, Fire Sealants)

## Integration of Passive Fire Safety Code Requirements in Building Design using BIM

# Safe Egress for tenants

Architects incorporate certain elements into their buildings that provide a **protected path of travel** from any point inside the building to a safe place outside or inside the building.

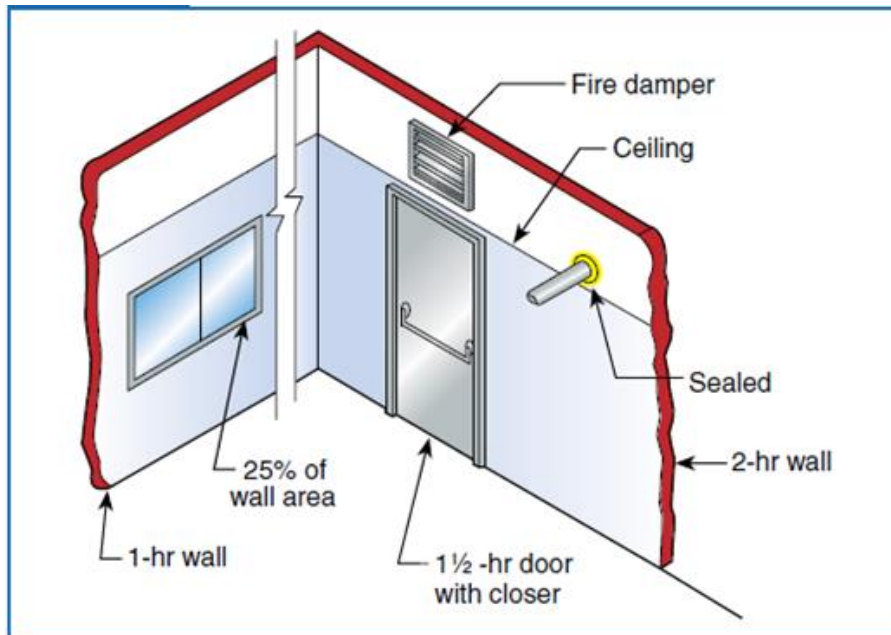

Typical penetrations of a fire barrier.



# Global Codes and Standards

## Goal of the Code

A goal of this *Code* is to provide an environment for the occupants that is reasonably safe from fire by the following means:

- (1)\* Protection of occupants not intimate with the initial fire development
- (2) Improvement of the survivability of occupants intimate with the initial fire development

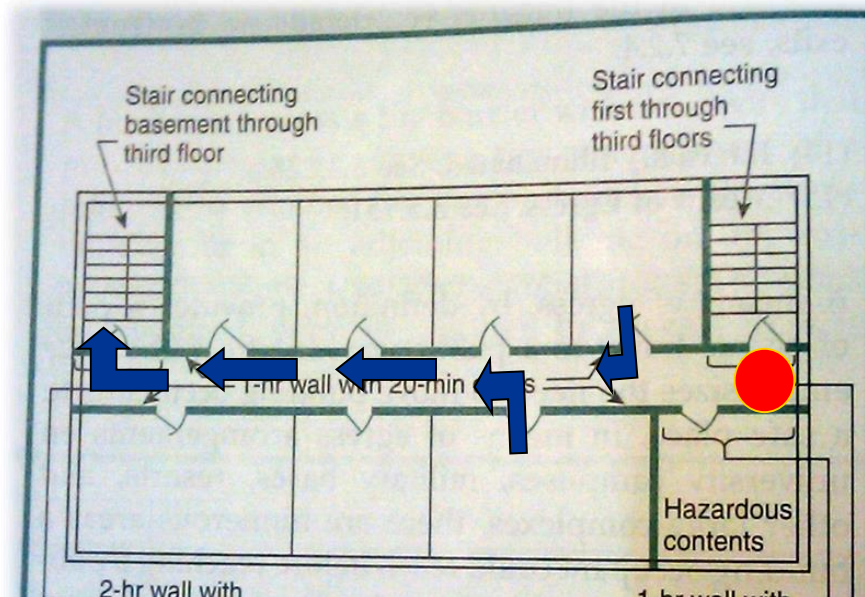

## 4.5 Fundamental Requirements

1. Provide for adequate safety **without dependence on any single safeguard.**
2. Provide an appropriate degree of life safety considering the size, shape, and nature of the occupancy.
3. Provide for backup or redundant egress arrangements.
4. Ensure that the **egress paths are clear, unobstructed, and unlocked.**
5. Ensure that the exits and egress routes are clearly marked to avoid confusion and provide the cues needed for their effective use.
6. Provide adequate lighting.
7. Ensure prompt occupant response by providing early warning of fire.
8. Ensure that required systems facilitate and enhance situation awareness.
9. Ensure the suitable **enclosure of vertical openings.**
10. Ensure compliance with applicable installation standards.
11. Maintain all required features in proper working order.

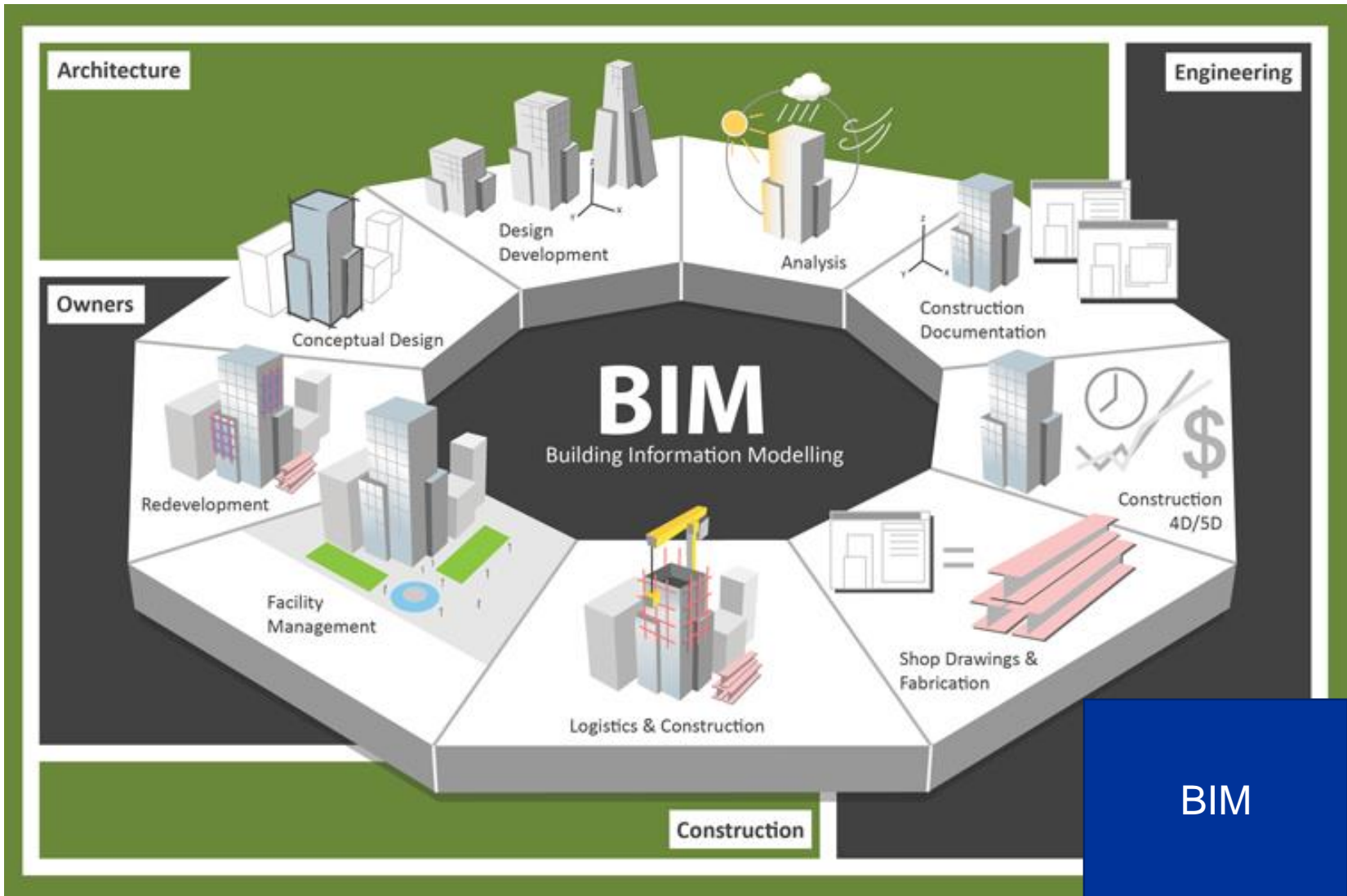



# BIM Definition

- A 3D model of building **X**
- A software. **X**
- Building Information Management **X**
- Building Information Model **X**



# BIM Definition

- A 3D model of building **X**
- A software. **X**
- Building Information Management **X**
- Building Information Modeling **✓**



# BIM Definition

- A 3D model of building **X**
- A software. **X**
- Building Information Management **X**
- Building Information Modeling **✓**

Several Software support BIM:

– Revit



AUTODESK®  
REVIT®

- ArchiCAD,
- Bentley Architecture,
- IDEA Architectural

and several others.





# BIM – Products



# BIM – Products

Properties

DOOR\_DR\_01  
DCT\_D1\_01

Doors (1) Edit Type

Constraints

Construction

Text

Materials and Finishes

Segments and Fittings

Dimensions

Identity Data

Phasing

Model Properties

General

Data

01_Hardware Set Number	1
Hardware 1-Qty	3
Hardware 1-Unit	Each
Hardware 1-Item	Hinges
Hardware 1-Item Code	3094-2BB
Hardware 1-Description	Hinges-101.6mmx 101.6mm ...
Hardware 1-Manufacturer	Dorma
Hardware 1-Finish	SSS.
Hardware 2-Qty	1
Hardware 2-Unit	Each
Hardware 2-Item	Lock
Hardware 2-Item Code	771 Lock
Hardware 2-Description	Mortise lock, LATCH and DE...
Hardware 2-Manufacturer	Dorma
Hardware 2-Finish	SSS
Hardware 3-Qty	1
Hardware 3-Unit	Each
Hardware 3-Item	Cylinder
Hardware 3-Item Code	Gege pExtra-DKZ
Hardware 3-Description	Europrofile Cylinder 35/35m...
Hardware 3-Manufacturer	KABA
Hardware 3-Finish	Ni
Hardware 4-Qty	1
Hardware 4-Unit	Each
Hardware 4-Item	Door Closer
Hardware 4-Item Code	ITS96-EN 2-4, HO G96N20
Hardware 4-Description	Door Closer, Concealed.-Adj...
Hardware 4-Manufacturer	Dorma

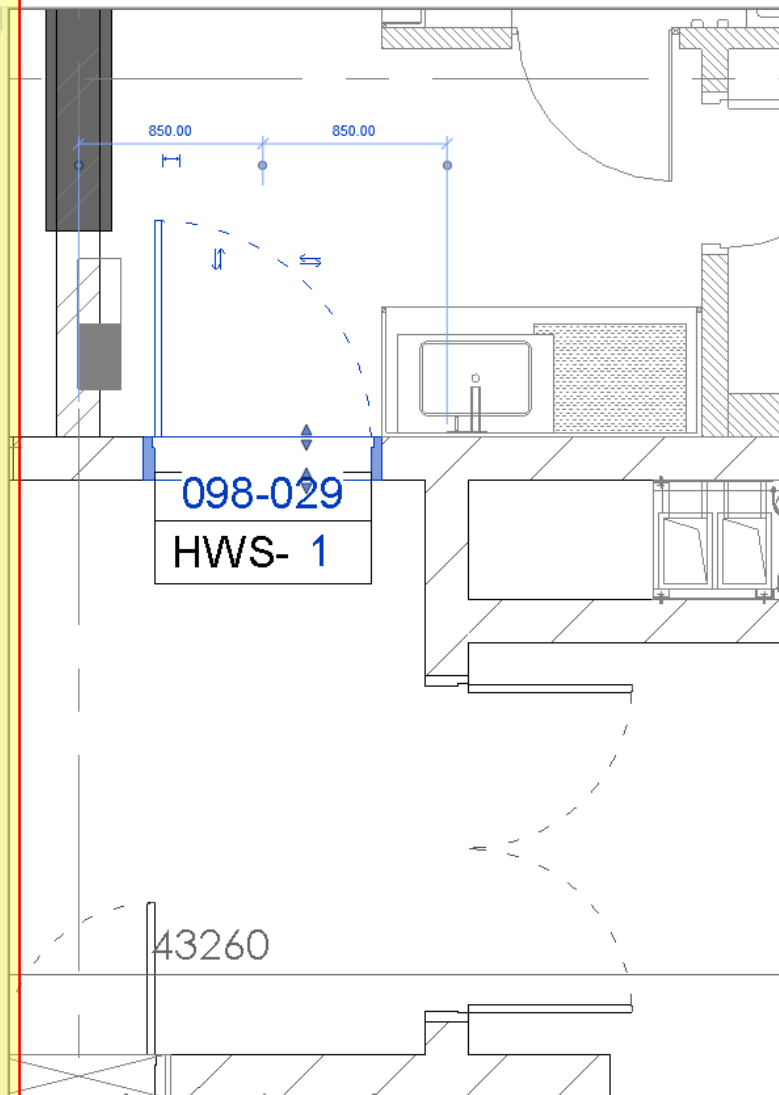

## Project Browser

- DOOR HARDWARE SPECIFICATION
- Floor Plan: 00\_GROUND FLOOR\_HW
  - Floor Plan: 01\_FIRST FLOOR\_HW
  - Floor Plan: 02\_SECOND FLOOR\_HW
  - Floor Plan: 03\_3RD FLOOR\_HW
  - Floor Plan: 04\_4TH FLOOR\_HW
  - Floor Plan: 05\_5TH FLOOR\_HW
  - Floor Plan: 06\_6TH FLOOR\_HW
  - Floor Plan: 07\_7TH FLOOR\_HW
  - Floor Plan: 08\_8TH FLOOR\_HW
  - Floor Plan: 09\_9TH FLOOR\_HW
  - Floor Plan: 10\_10TH FLOOR\_HW
  - Floor Plan: 11\_11TH FLOOR\_HW
  - Floor Plan: 12\_12TH FLOOR\_HW
  - Floor Plan: 13\_13TH FLOOR\_HW
  - Floor Plan: 14\_14TH FLOOR\_HW
  - Floor Plan: 15\_15TH FLOOR\_HW
  - Floor Plan: 16\_16TH FLOOR\_HW
  - Floor Plan: BASEMENT 01\_HW
  - Floor Plan: BASEMENT 02\_HW

# Compartmentation

NFPA 101, Life Safety Code – Ch. 8, Construction and Compartmentation,  
8.2.2.2 Fire Compartments shall be formed with fire barriers.

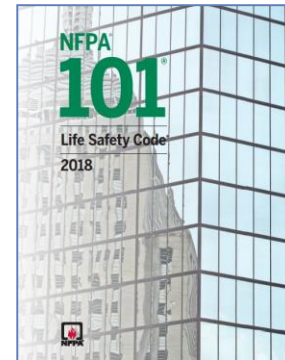
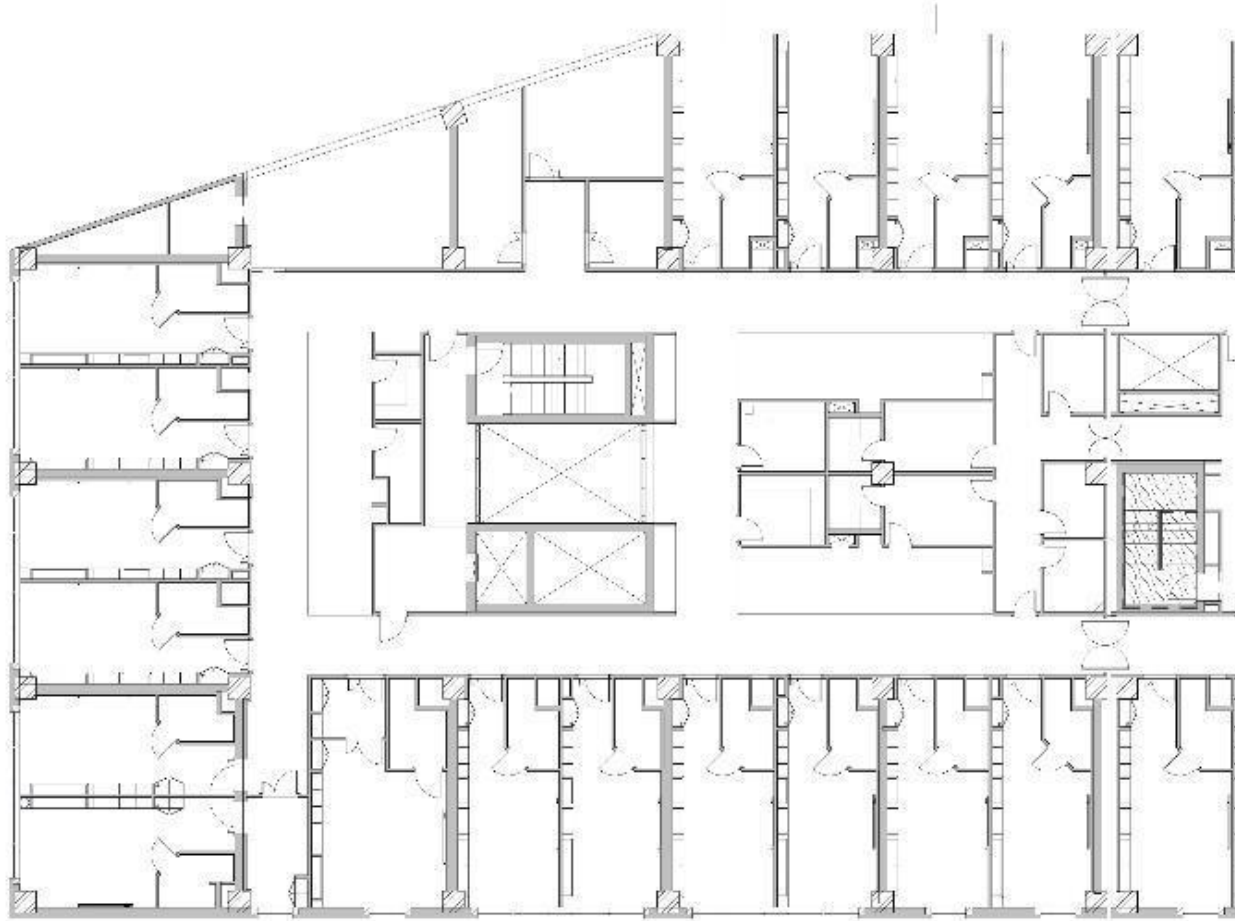

# Compartmentation

NFPA 101, Life Safety Code – Ch. 8, Construction and Compartmentation, 8.2.2.2 Fire Compartments shall be formed with fire barriers.

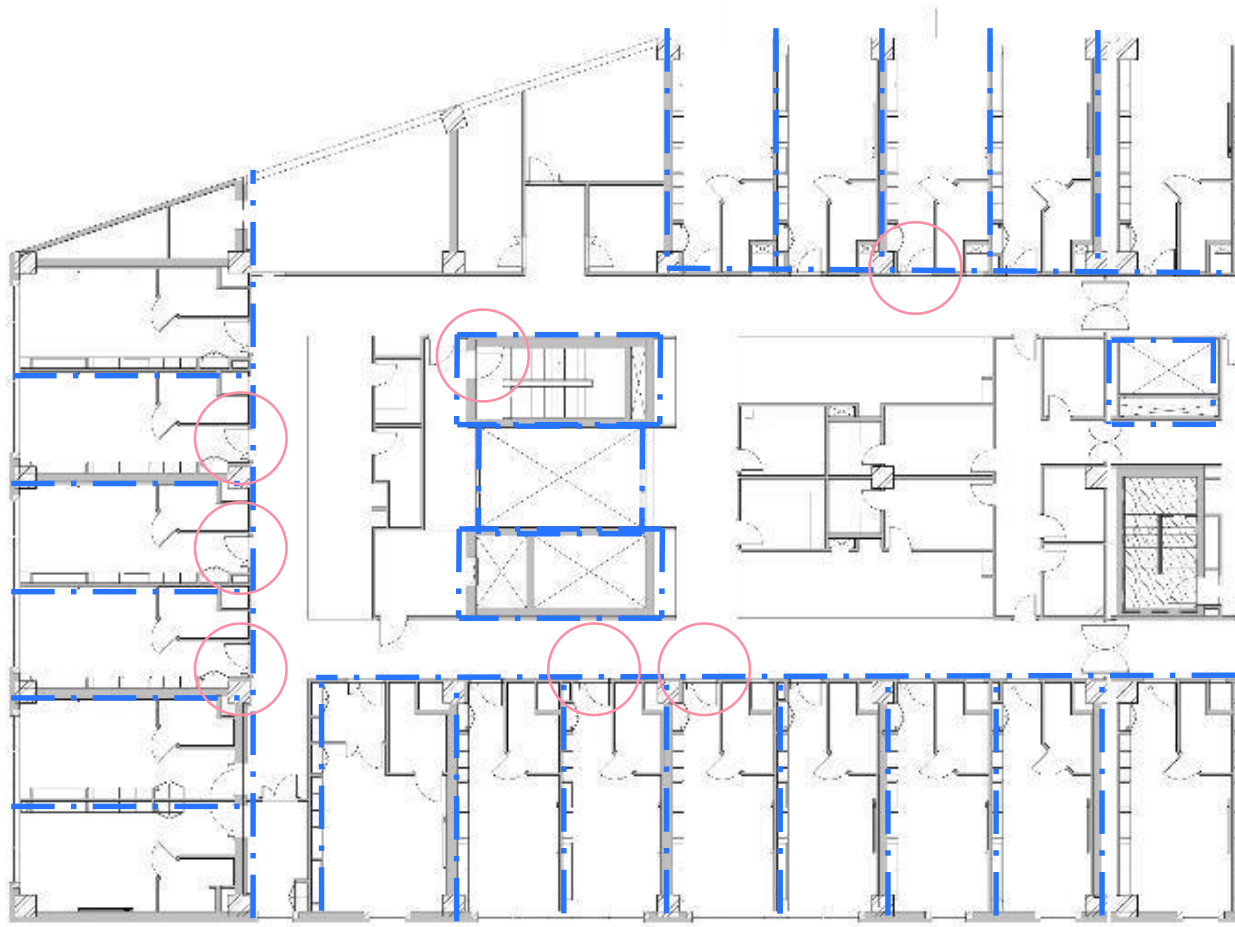
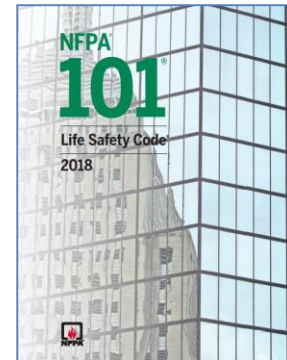

# Compartmentation

Fire Rated doors to be Self Closing and Self Latching

**6.1.3 Operation of Doors.** All swinging doors shall be closed and latched at the time of fire.

## 6.1.3.2 Self-Closing Doors.

**6.1.3.2.1** Self-closing doors shall swing easily and freely and shall be equipped with a closing device to cause the door to close and latch each time it is opened.

**6.1.3.2.2** The closing mechanism shall not have a hold-open feature.

Rated Door Closer



Rated Lock with Latch

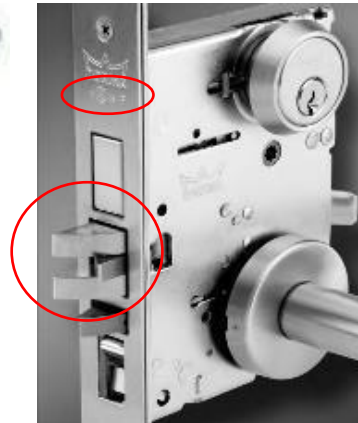

NFPA® 80  
Standard for  
Fire Doors and  
Other Opening Protectives

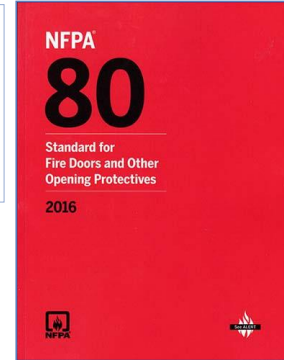

# Compartmentation

NFPA 101, Life Safety Code – Ch. 8, Construction and Compartmentation,  
8.2.2.2 Fire Compartments shall be formed with fire barriers.

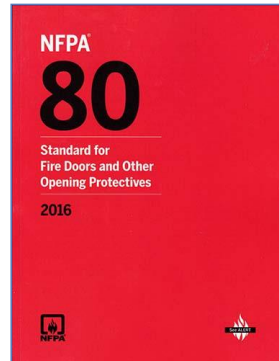
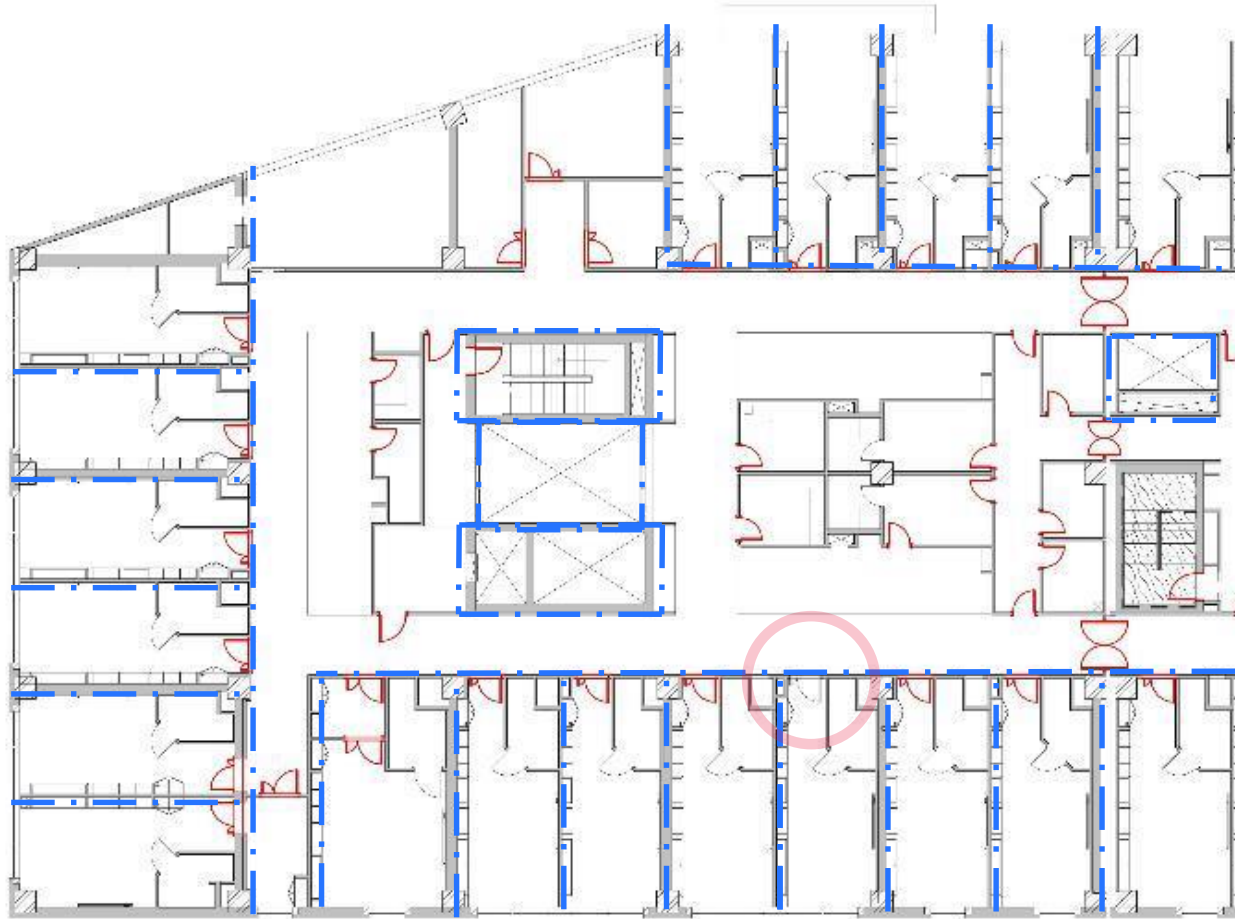

# Occupant Load / Number of Exits

## Occupant Load

**7.3.1.1.1** The total capacity of the means of egress for any story, balcony, tier, or other occupied space shall be sufficient for the occupant load thereof.

## Number of Exits

**7.4.1.2** The number of means of egress from any story or portion thereof, other than for existing buildings as permitted in Chapters 11 through 43, shall be as follows:

- (1) Occupant load more than 500 but not more than 1000 — not less than 3
- (2) Occupant load more than 1000 — not less than 4

## Health Care Occupancies

**18.2.4.1** Not less than two exits shall be provided on every story.

## Storage Occupancies

**42.2.4.1** The number of means of egress shall comply with any of the following:

- (1) In low hazard storage occupancies, a single means of egress shall be permitted from any story or section.

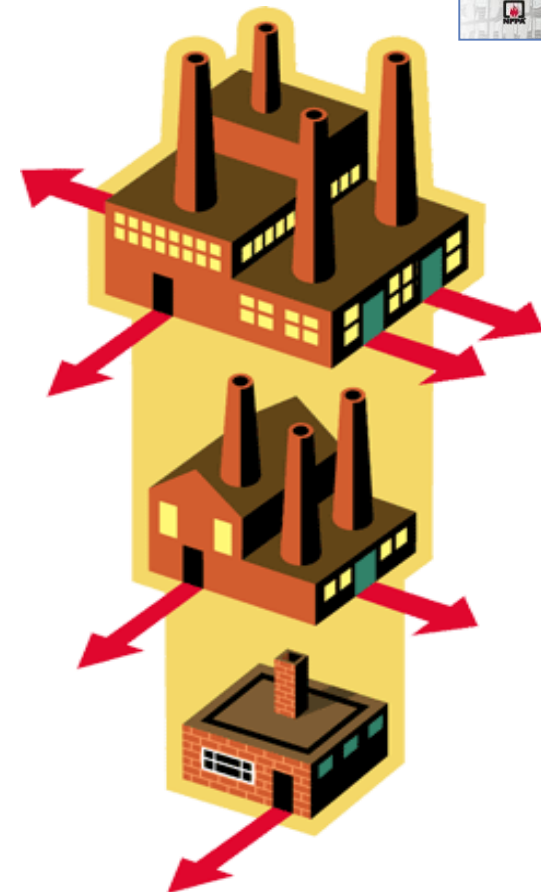
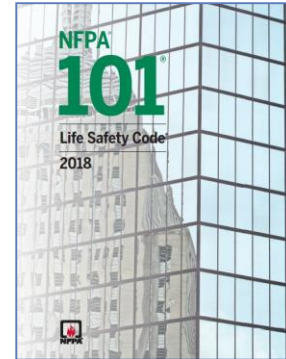

# Occupant Load / Number of Exits

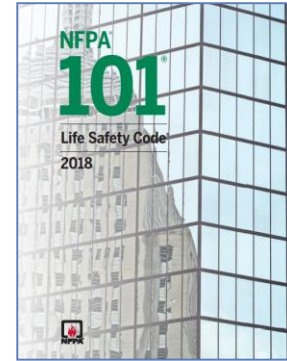

Code Compliance



# Occupant Load / Number of Exits

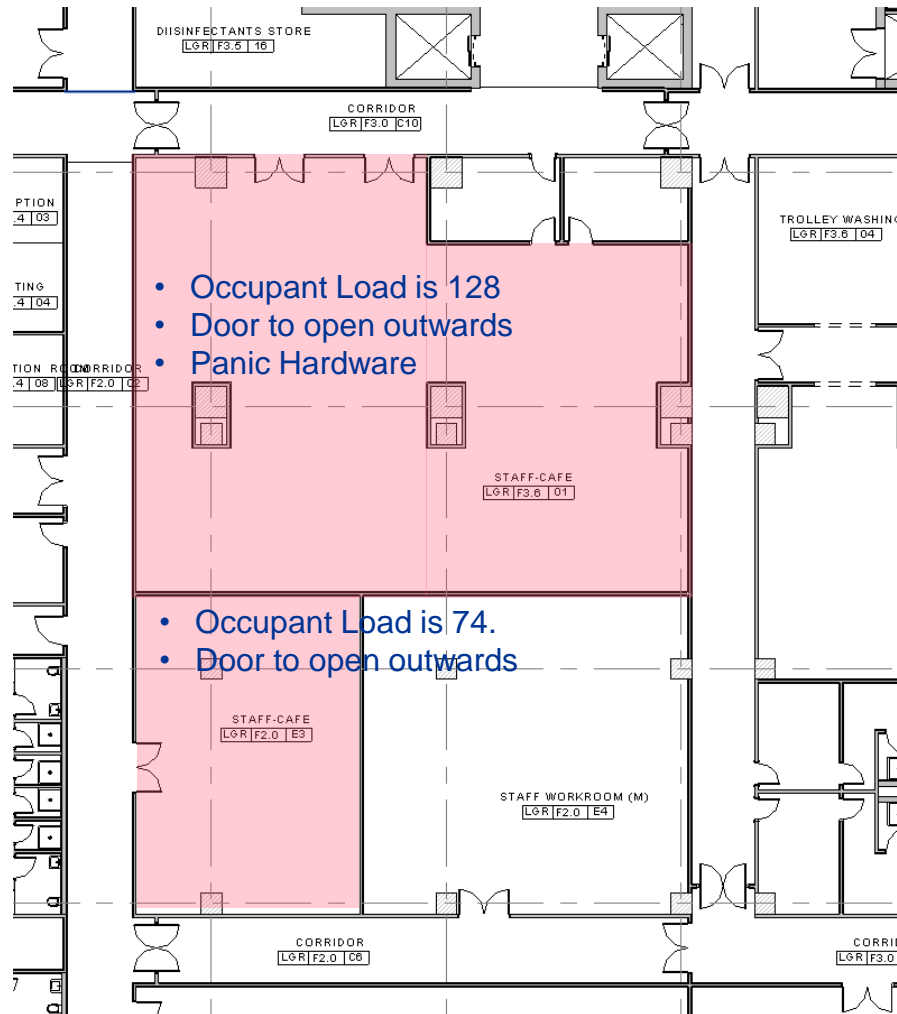
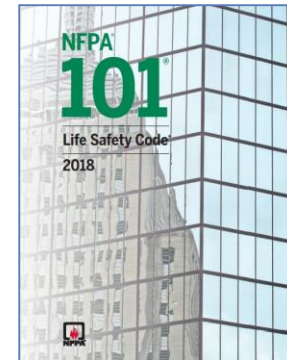

- Occupant Load is 128
- Door to open outwards
- Panic Hardware

- Occupant Load is 74.
- Door to open outwards

- Occupant Load
- Door to Open Outwards
- Panic Hardware
- Door Width
- Number of doors
- Location of doors
- Common Path of Travel
- Travel Distance
- Compartmentation

Code Compliance

# Egress

## Emergency Exit/Escape doors – Swing doors

**12.2.2.2.3** Any door in a required means of egress from an area having an **occupant load of 100 or more persons** shall be permitted to be provided with a latch or lock only if the latch or lock is **panic hardware or fire exit hardware** complying with 7.2.1.7, unless otherwise permitted by the following:

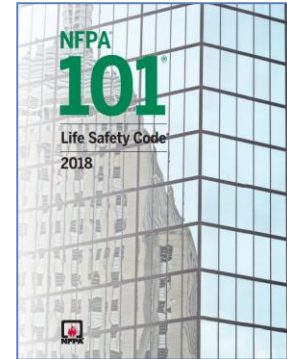

Chained Panic/Exit hardware for security. ❌



DORMA DE9000: Delayed Egress Panic Bar ✅

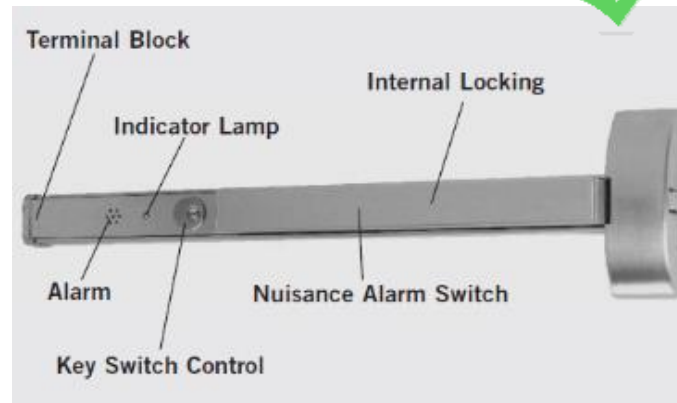

# Egress

## Emergency Exit/Escape doors – Swing doors

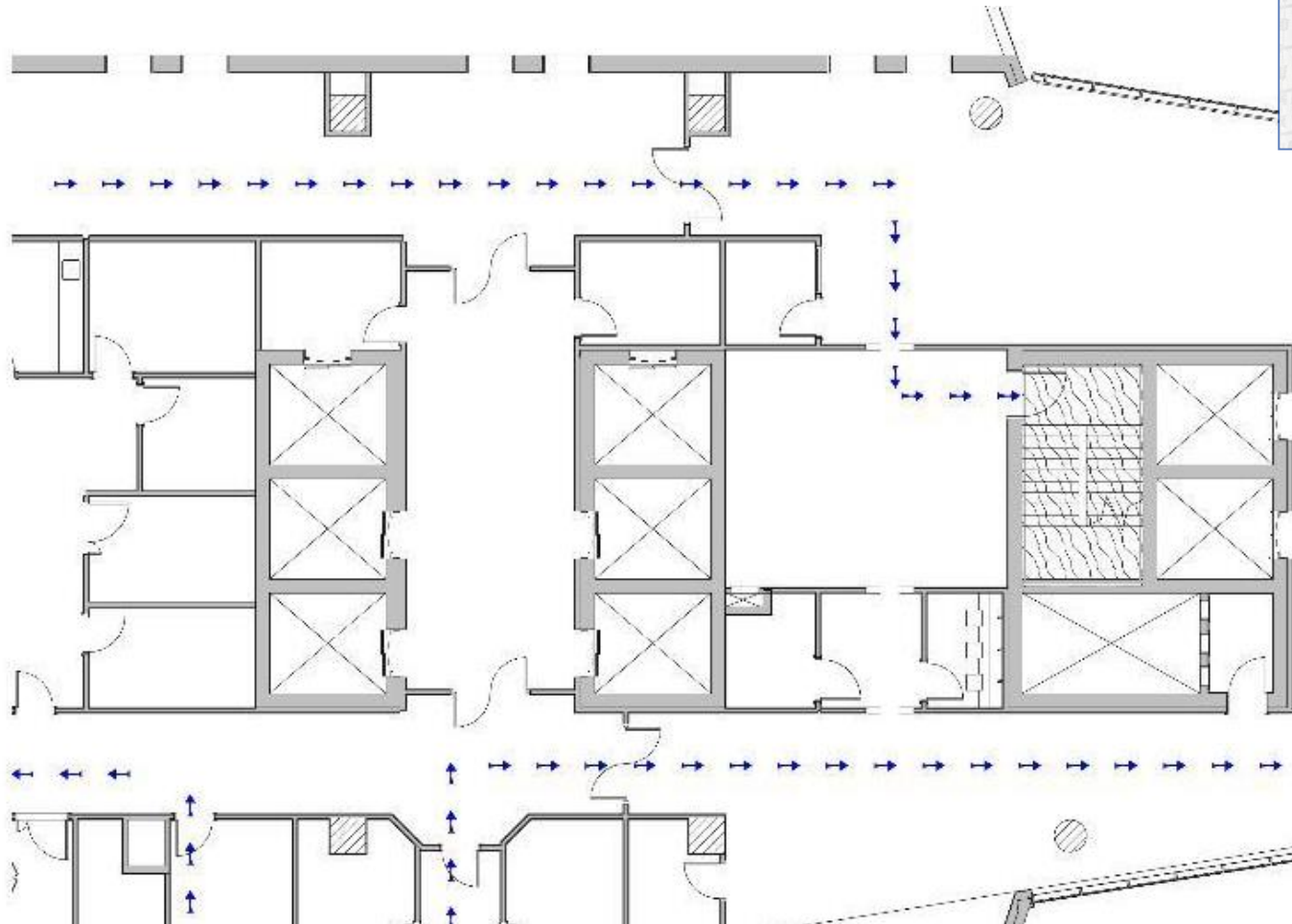
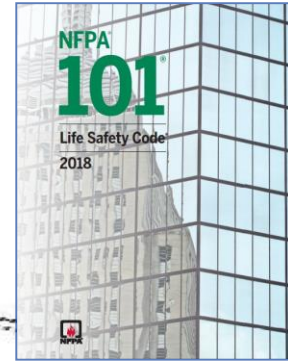

# Egress

## Emergency Exit/Escape doors – Swing doors

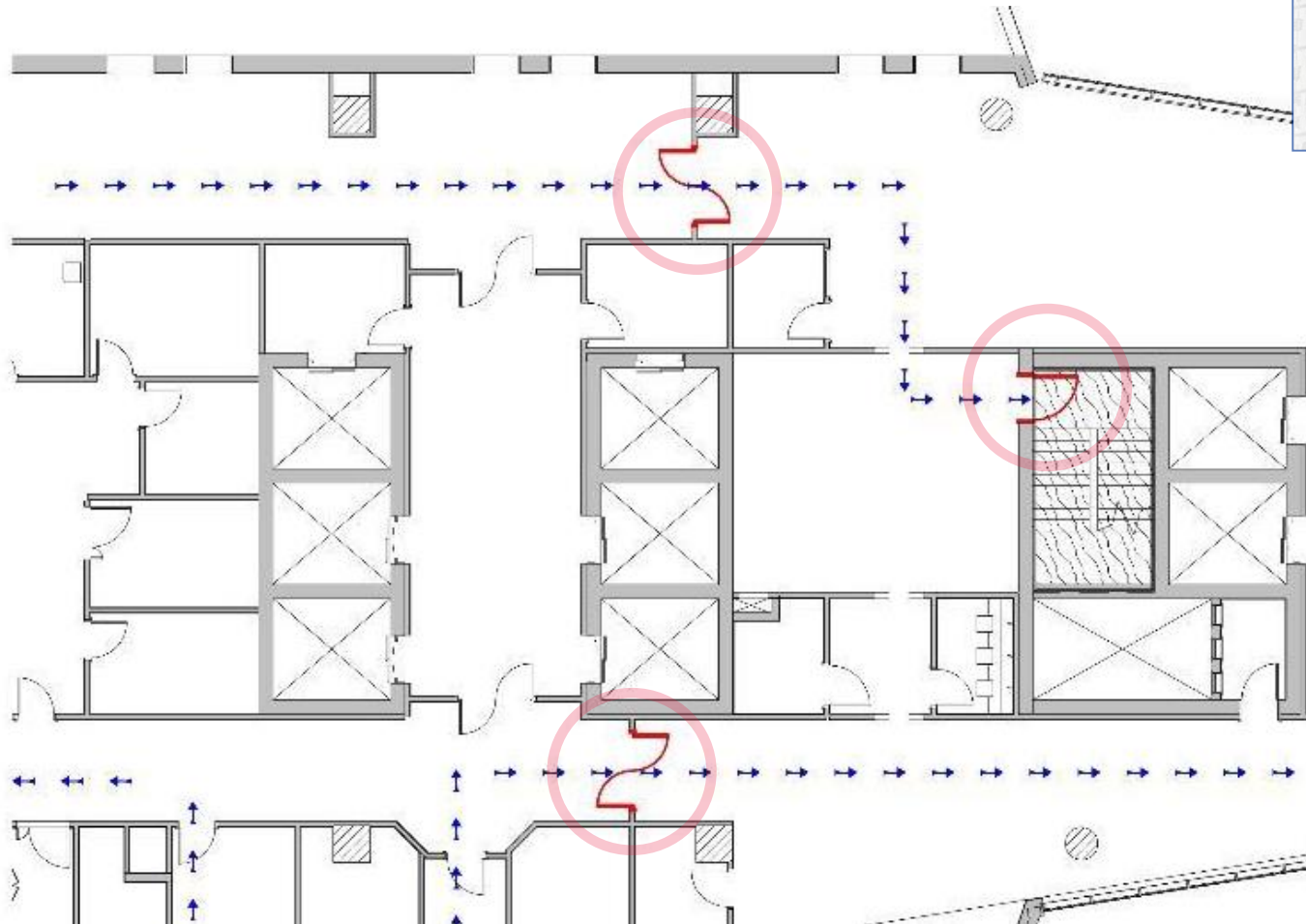
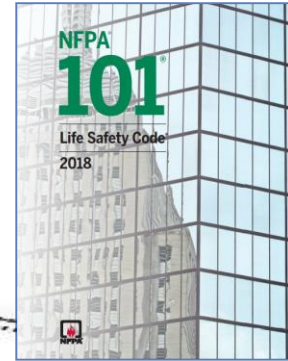

# Egress

## Emergency Exit/Escape doors - Entrance Revolving doors

### 7.2.1.10 Revolving Door Assemblies.

7.2.1.10.1 Revolving door assemblies, whether used or not used in the means of egress, shall comply with the following:

- (1) Revolving door wings shall be capable of being collapsed into a book-fold position, unless they are existing revolving doors approved by the authority having jurisdiction.
- (2) When revolving door wings are collapsed into the book-fold position, the parallel egress paths formed shall provide an aggregate width of 36 in. (915 mm), unless they are approved existing revolving door assemblies.
- (6) Each revolving door assembly shall have a conforming side-hinged swinging door assembly in the same wall as the revolving door within 10 ft (3050 mm) of the revolving door, unless one of the following conditions applies:

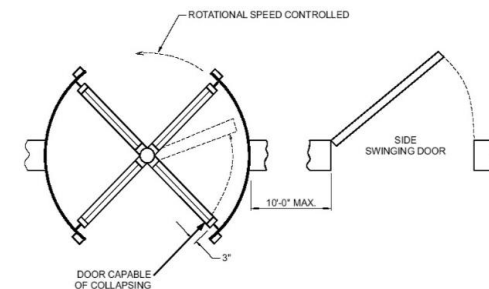
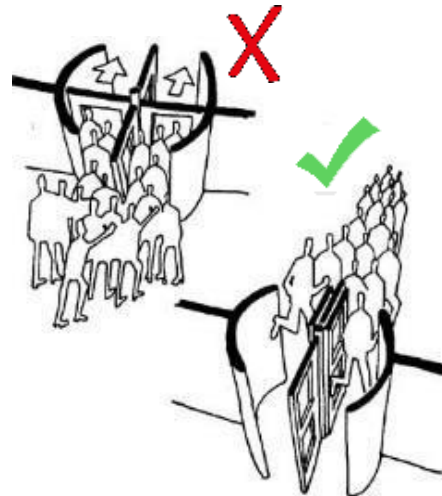
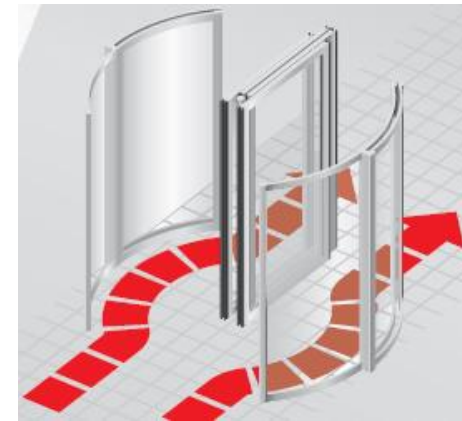
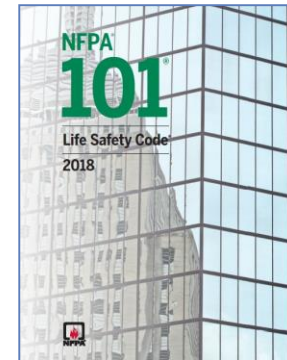

# Egress

## Emergency Exit/Escape doors - Entrance Revolving doors

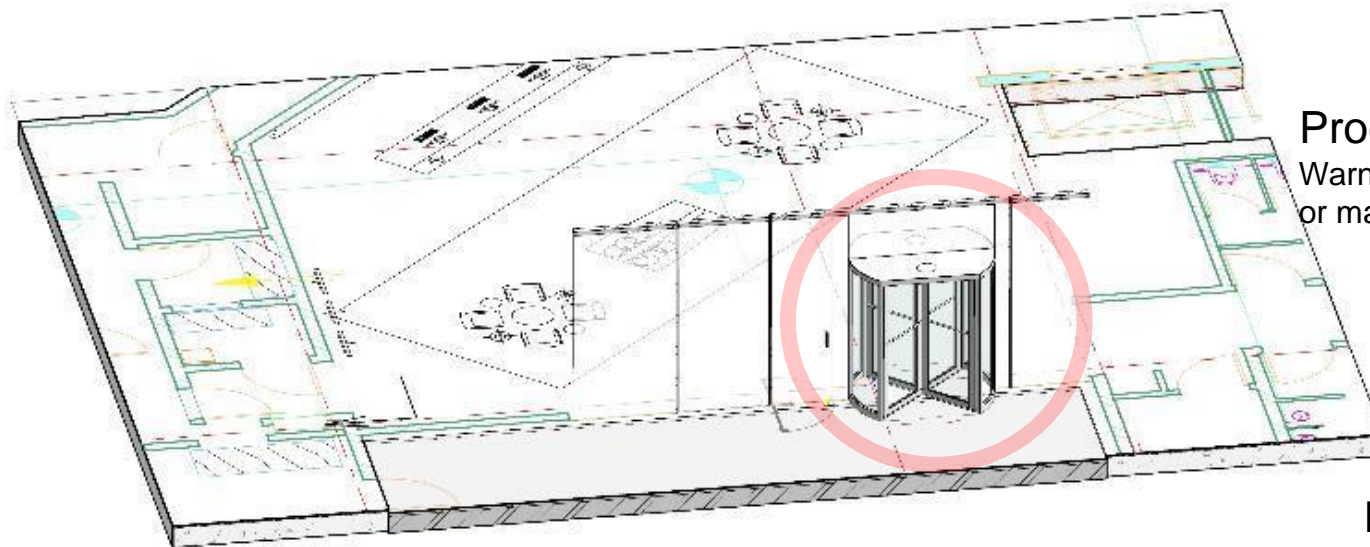
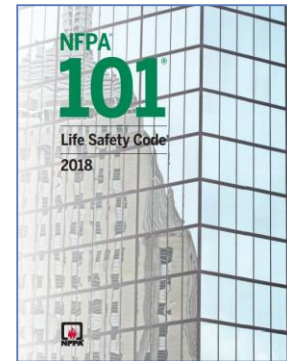

### Product Constraints

Warning text will be visible if minimum or maximum sizes exceeded

NFPA 7.2.1.10

Code Compliance

Check as per NFPA 7.2.1.10

1. Capable of being Collapsed into book-fold position.
2. In book fold position Parallel Egress paths shall provide an width of 36 in.(915mm).
3. Should have a confirming Side-hinged swinging door assembly within 10ft (3050mm) from the revolving door.

# Egress

Emergency Exit/Escape doors - Entrance Revolving doors

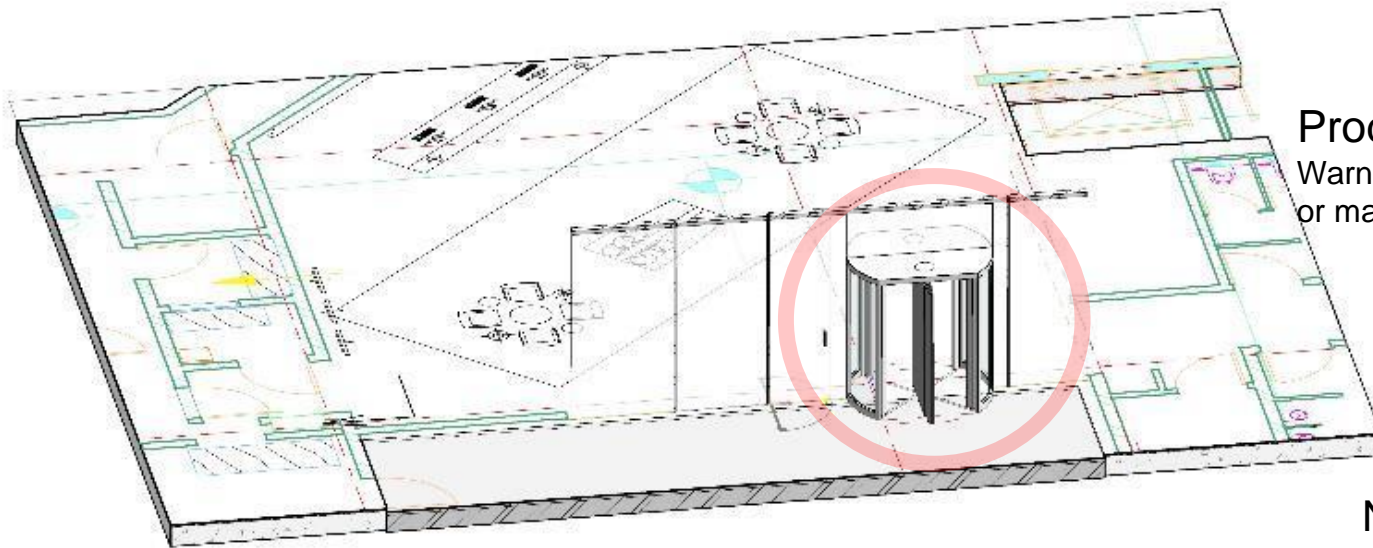
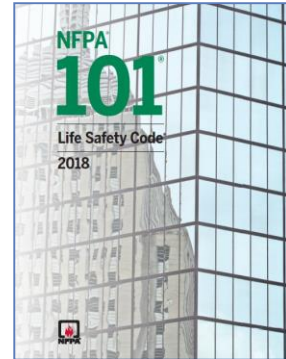

Product Constraints

Warning text will be visible if minimum or maximum sizes exceeded

NFPA 7.2.1.10

Code Compliance

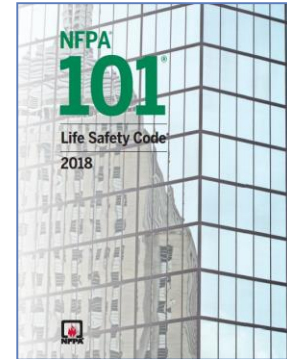

### 7.2.1.11 Turnstiles.

7.2.1.11.1.2 Where turnstiles are approved by the authority having jurisdiction and permitted in Chapters 11 through 43, each turnstile shall be credited for a capacity of 50 persons, provided that such turnstiles meet the following criteria:

- (1) They freewheel in the egress direction when primary power is lost, and freewheel in the direction of egress travel upon manual release by an employee assigned in the area.
- (2) They are not given credit for more than 50 percent of the required egress width.
- (3) They are not in excess of 39 in. (990 mm) in height and have a clear width of not less than 16½ in. (420 mm).

7.2.1.11.2 Turnstiles exceeding 39 in. (990 mm) in height shall meet the requirements for revolving door assemblies in 7.2.1.10.





# Egress

## Emergency Exit/Escape doors - Turnstiles

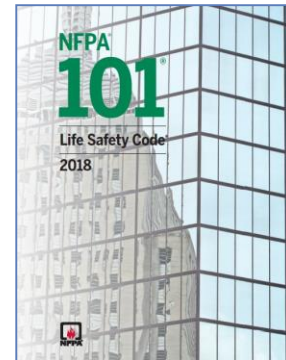
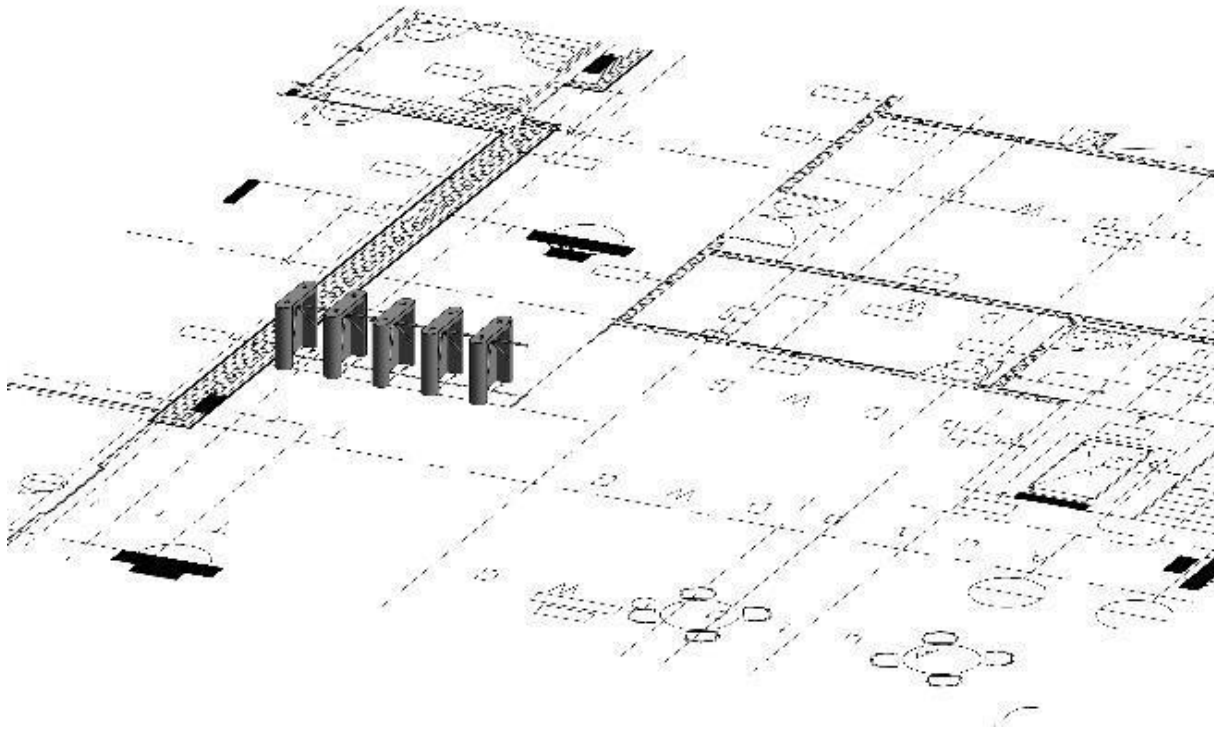

### Product Constraints

Warning text will be visible if minimum or maximum sizes exceeded

### NFPA 7.2.1.11

### Code Compliance

Check the following Criteria as per NFPA 7.2.1.11

1. Freewheel in direction of egress when power is lost.
2. Freewheel in the direction of egress travel upon manual release.
3. Maximum height of 39 in (910mm) and Width not less than 16 1/2 in. (420mm)

# BIM to VR, AR, MR...



VR

AR



MR

# BIM and Future



## Facility Managers

Using BIM, Sensors, Connectivity, AI . . . . .



- Live information
- Monitor and Control
- IoT
- Re-Order, Maintain
- Smart Dust / Motes



## Clients

Using VR, AR, MR



- Walkthrough at his will
- Interaction with model
- Select objects
- Make changes
- See effects
- Make Decisions
- Issue approval



## Designers

Using Professional Software



- 3D model,
- Information (products and Codes related)
- Walkthrough
- Objects selection

# BIM





# Riyadh Conference

April 09, 2019, Mövenpick Hotel - Riyadh

## Thank you!

### Integration of Passive Fire Safety Code Requirements in Building Design using BIM, AR, VR and AI

